

MAKING RAILROAD HISTORY™
WALTHERS®



Engineered Bridge System™

With a growing selection of prototype bridge styles and accessories, the Cornerstone Engineered Bridge System makes it easy to plan and build an authentic HO Scale bridge from start to finish.

On this page, you'll find links to the current selection of kits and accessories – check back for more new items coming soon – along with some “bridge basics” to help you get started.

The “right” bridge for your railroad

Some of the same decisions facing engineers on the prototype, such as the need for extra clearance, the length of the span and weight of passing trains enter into our decisions about what bridges belong on our railroad. But unlike the prototype, we're also concerned about era, and a covered wooden bridge of the 1870s just doesn't work on a layout running SD70s! Here are some general prototype guidelines to consider.

Railroads like deck bridges best. Using less material, they're cost effective, easier to build and provide unlimited clearance at the top and sides.

Designers have to think about what's happening below and alongside a bridge too. If extra room is needed for passing ships, another railroad or a highway, a through bridge will be used. In extreme cases, a moveable bridge may be needed on a waterway.

The overall length of a bridge is also a deciding factor, so that trusses or stronger plate girders may be specified for the support structure.

If extra support is needed and room is available, piers may be constructed. But for especially long spans, several bridges will be joined end to end, each meeting in the middle of a pier. It's also common to see different bridge styles used together on these spans.

Modeling a curved bridge can make for some fun kitbashing, but remember, tracks can curve, bridges can't! Since they cost more, curved spans are pretty rare on the prototype. But if it's unavoidable, the deck of a standard design may be widened to accommodate the curve. Where a longer curve is needed, several short, straight bridges will be used, meeting at an angle.

Bridges 101

Railroad bridges are one of two basic types: Deck Bridges have their support structure below the tracks while a Through Bridge has supports alongside.

Depending on how the bridge is supported, it may be described as a:

Beam - a simple deck bridge made from large steel beams placed side by side. Used for short spans such as culverts.

Truss - Triangular supports that strengthen the overall structure, used on both deck and through bridges. Used for medium-length spans.

Plate Girder - Steel plates riveted together into a larger and durable support structure, used on both deck and through bridges and for longer spans.

Other essential parts of a bridge include:

Abutments - Built at both ends where the structure joins the land, functions as a retaining wall and supports the bridge at its center.

Approaches - graded right-of-way leading up and on to the bridge.

Approach Spans - a series of bridges leading to a center span, used to cross a wider area.

Pier - A smaller support at the mid-point of longer bridges.

Trestle - While we think of the entire structure as a trestle, this actually refers to the open, braced framework of wood or steel supporting the deck.

Scenery or structures first?

Whether starting with empty benchwork or reworking existing scenery, bridge construction can be a fun project at any point in the life of your layout.

Selecting the type of bridge you want first will help determine how much work is needed. From there, you can plan out each phase of scenery construction and put together a bill of materials.

Common Bridge Arrangements

Combinations with Girder Bridges and Truss Bridges

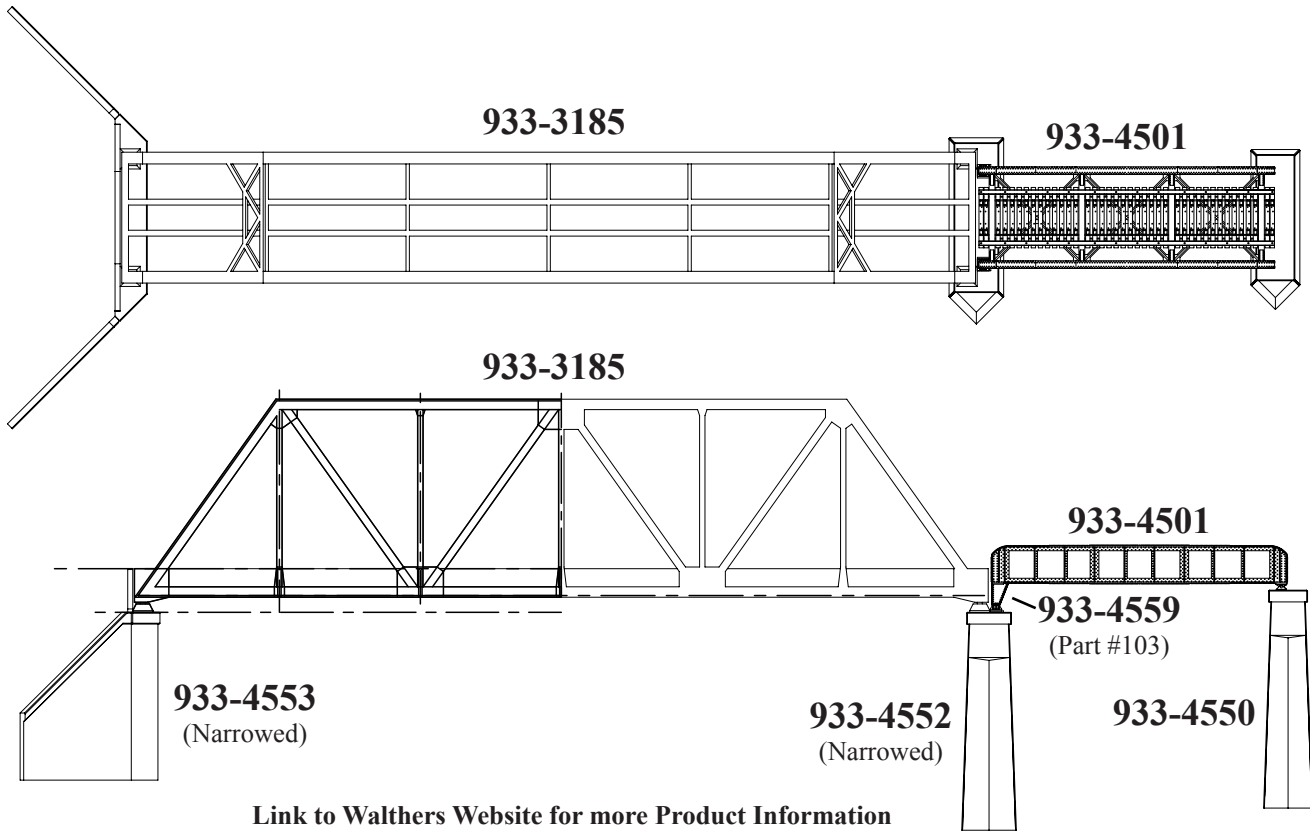
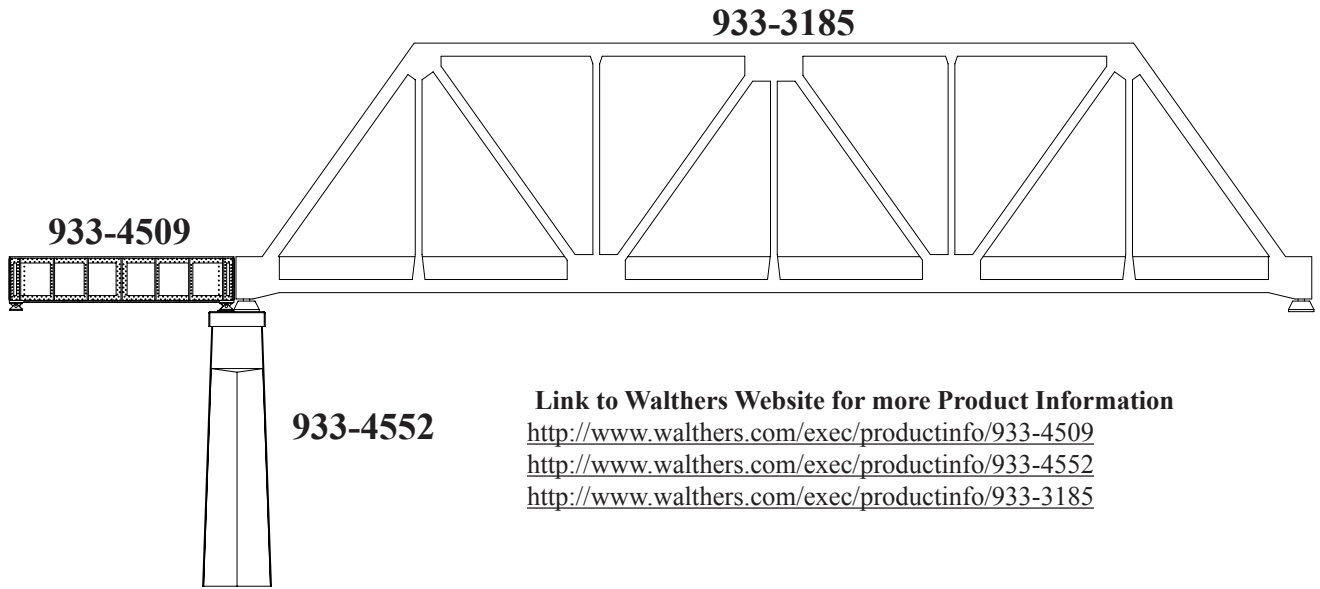

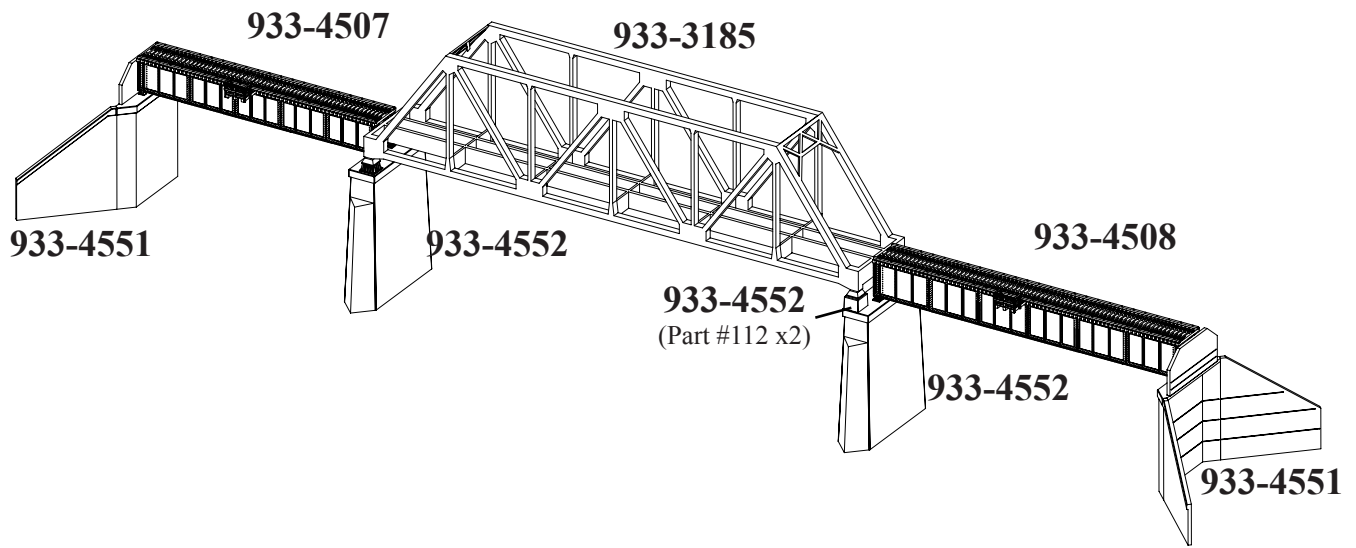

Link to Walthers Website for more Product Information

<http://www.walthers.com/exec/productinfo/933-3185>

<http://www.walthers.com/exec/productinfo/933-4507>

<http://www.walthers.com/exec/productinfo/933-4508>

<http://www.walthers.com/exec/productinfo/933-4551>

<http://www.walthers.com/exec/productinfo/933-4552>

<http://www.walthers.com/exec/productinfo/933-4559>

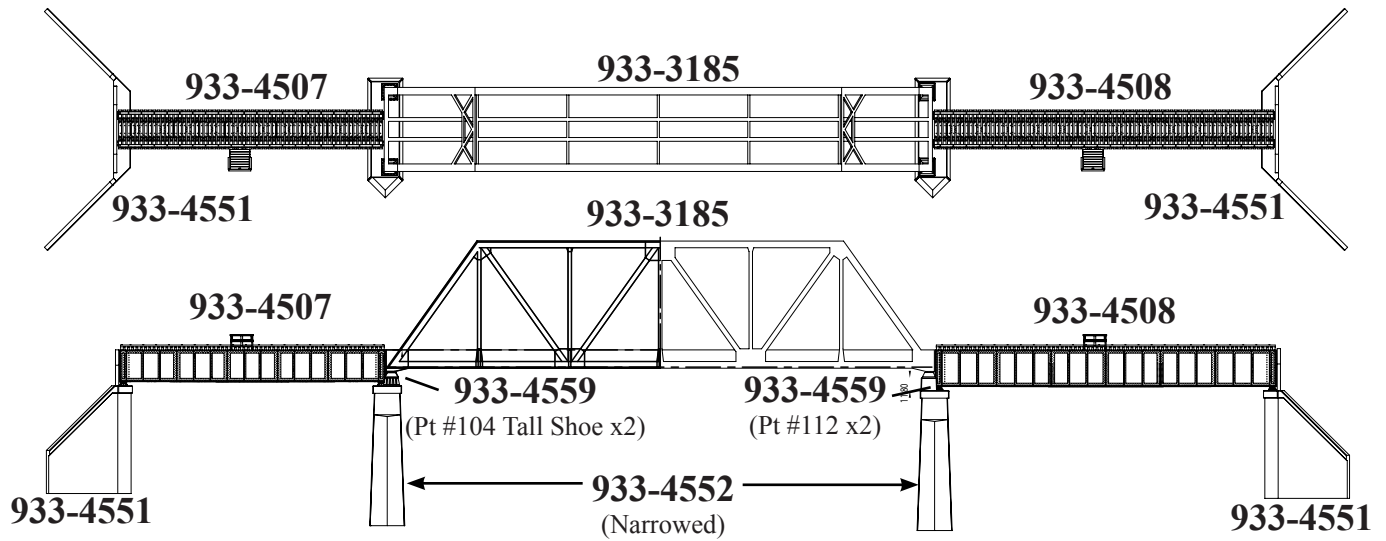

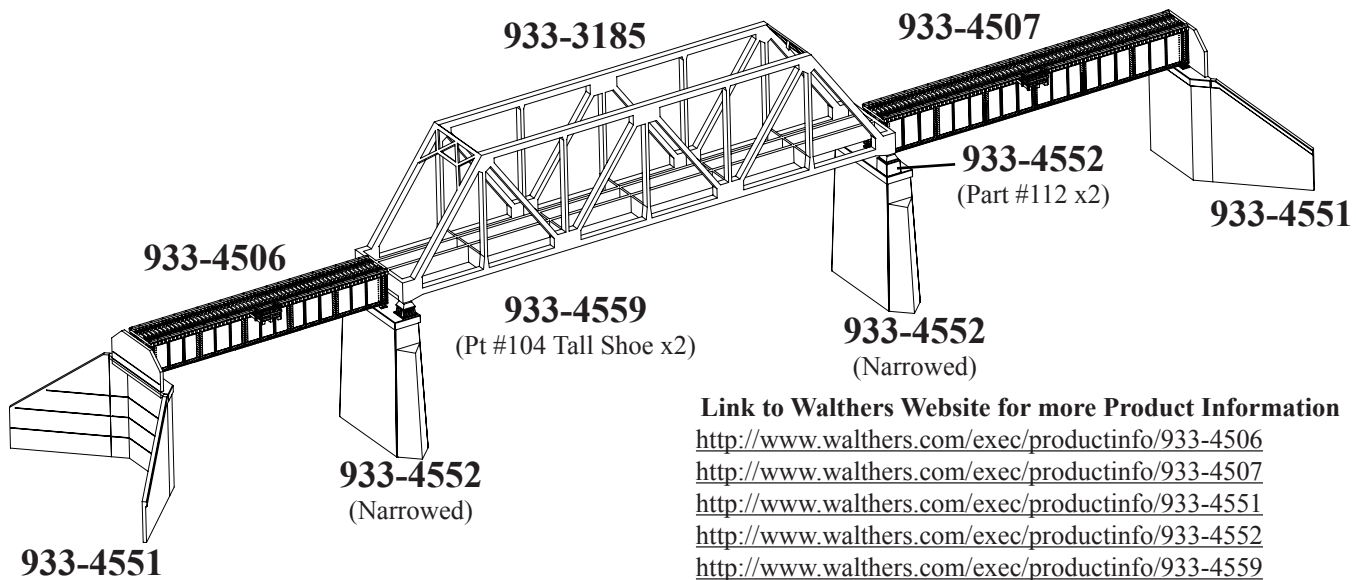

Combinations with deck truss bridges

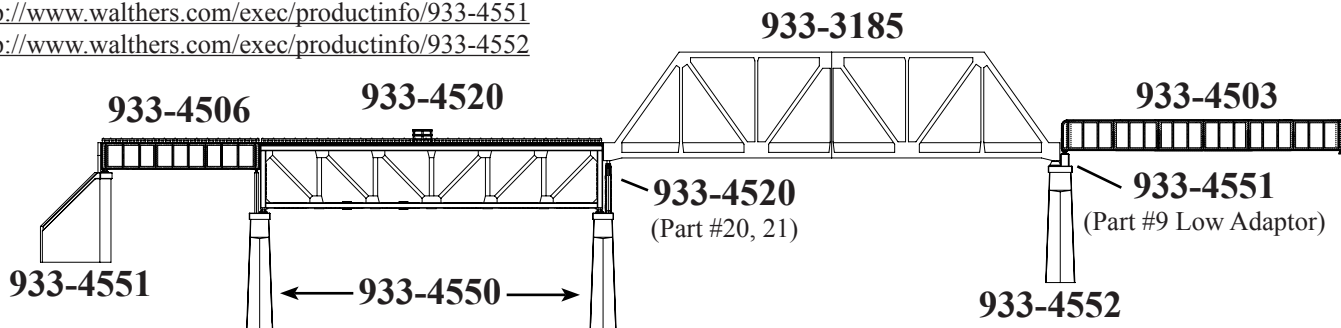
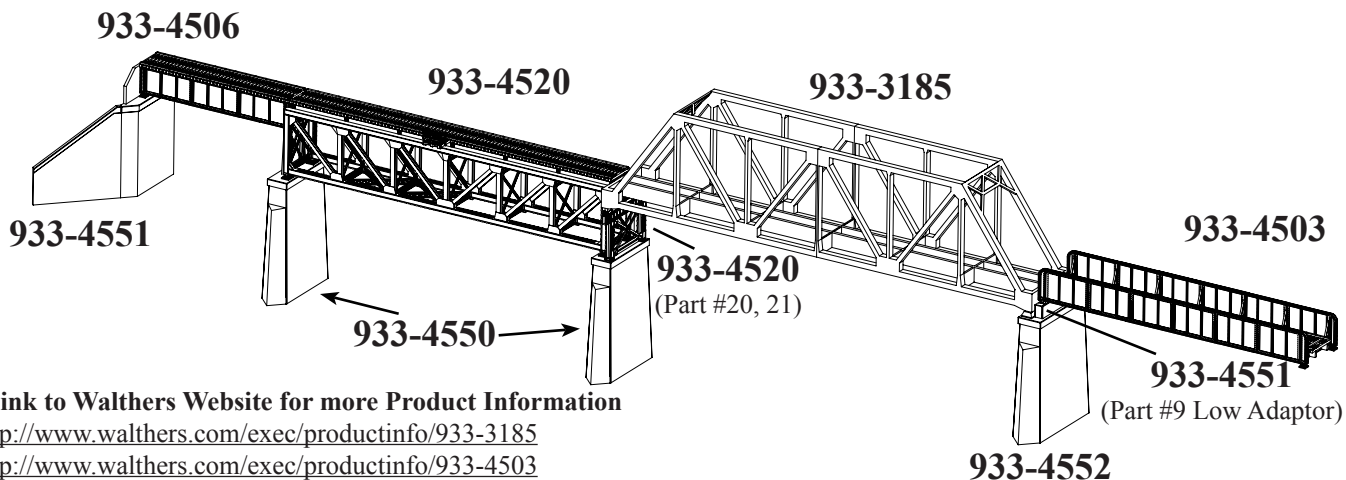

Combinations using multiple girder bridges

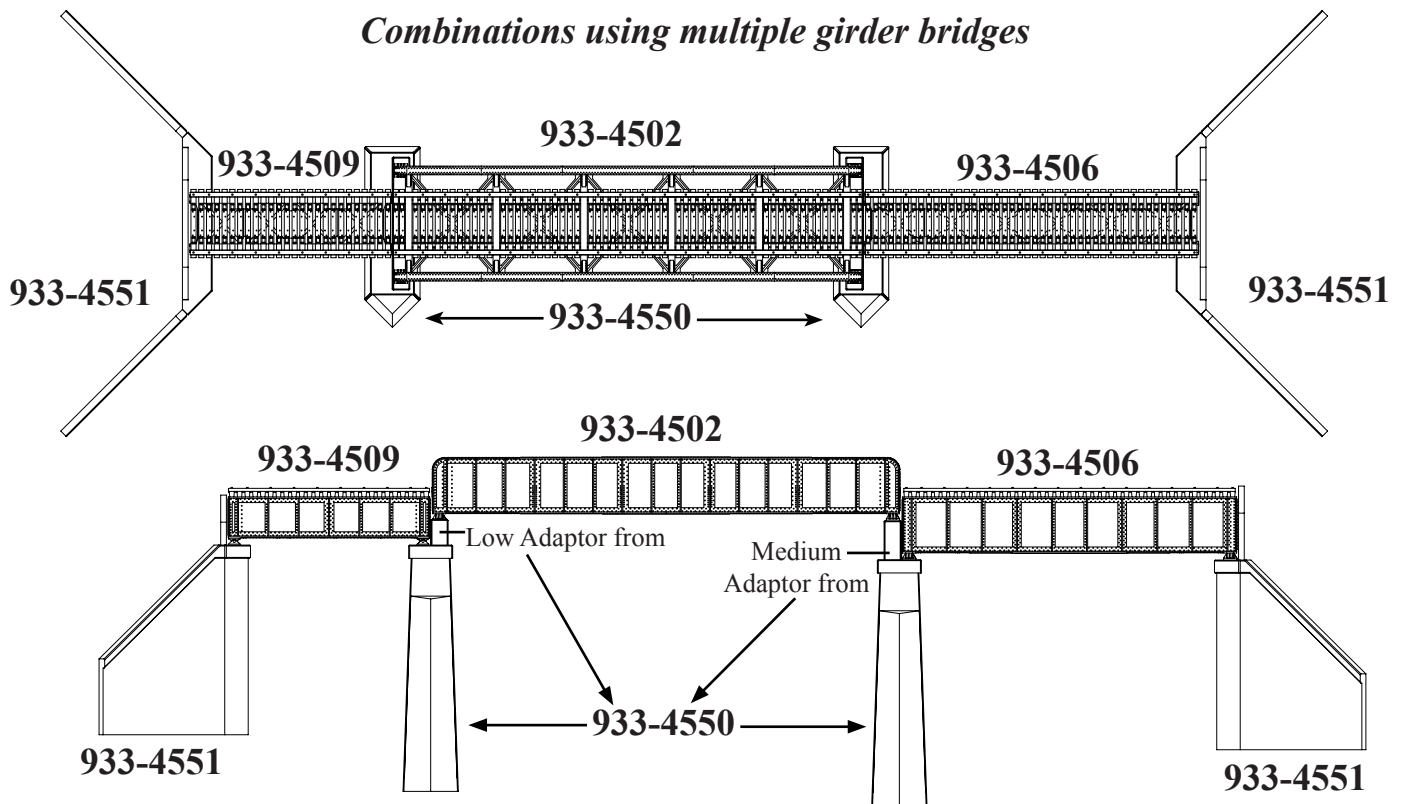

Link to Walthers Website for more Product Information

<http://www.walthers.com/exec/productinfo/933-4502>

<http://www.walthers.com/exec/productinfo/933-4506>

<http://www.walthers.com/exec/productinfo/933-4509>

<http://www.walthers.com/exec/productinfo/933-4550>

<http://www.walthers.com/exec/productinfo/933-4551>

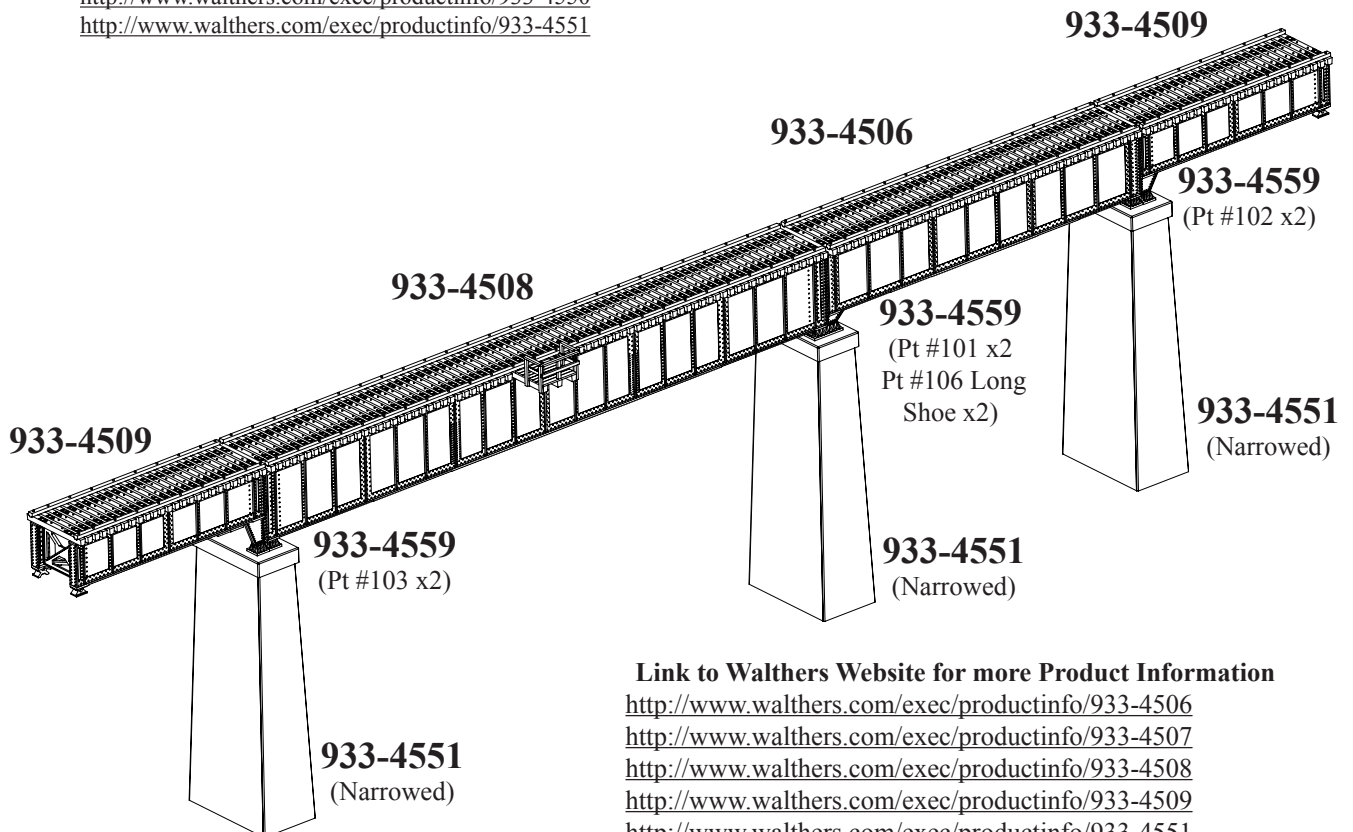

Link to Walthers Website for more Product Information

<http://www.walthers.com/exec/productinfo/933-4506>

<http://www.walthers.com/exec/productinfo/933-4507>

<http://www.walthers.com/exec/productinfo/933-4508>

<http://www.walthers.com/exec/productinfo/933-4509>

<http://www.walthers.com/exec/productinfo/933-4551>

<http://www.walthers.com/exec/productinfo/933-4559>

Multiple Track Bridges

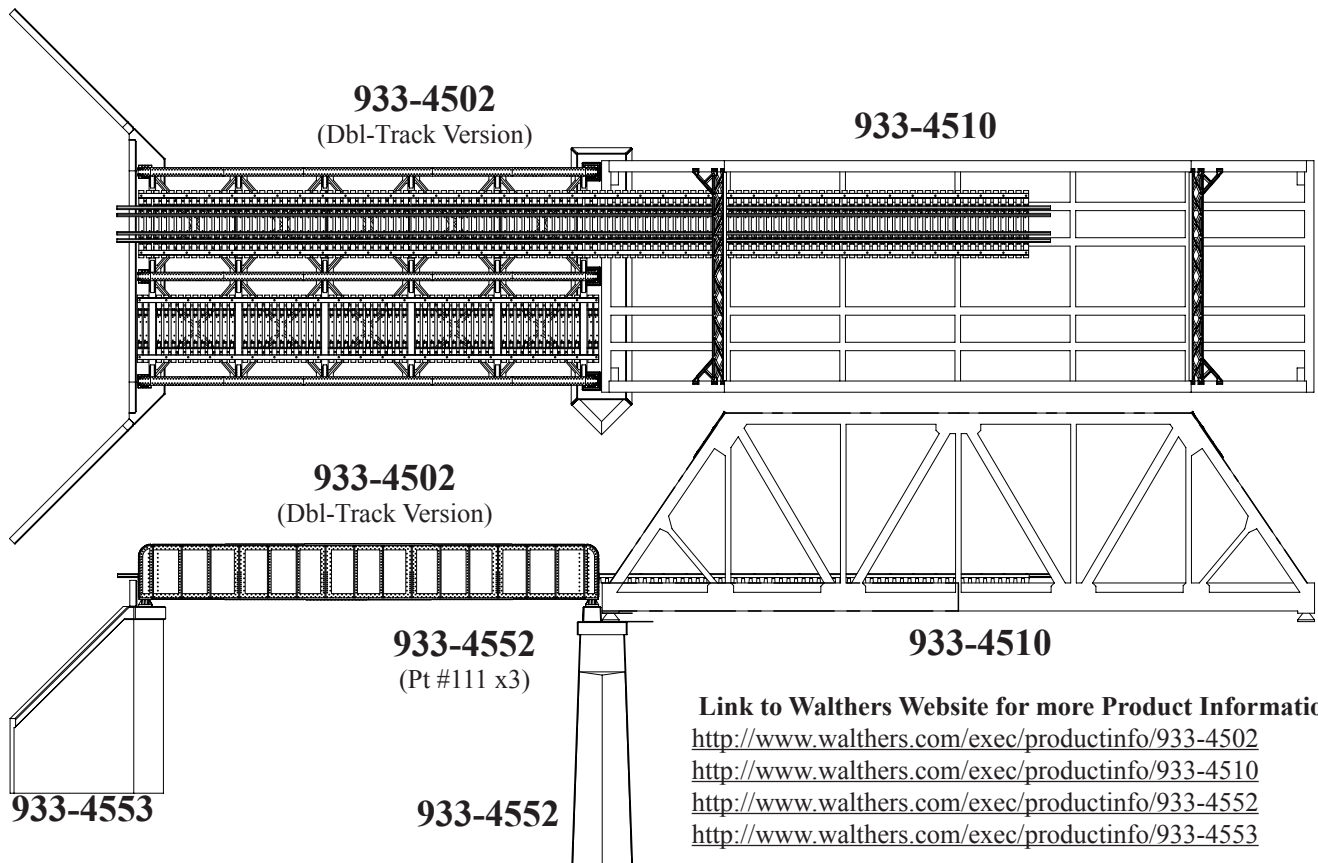

Link to Walthers Website for more Product Information

<http://www.walthers.com/exec/productinfo/933-4502>

<http://www.walthers.com/exec/productinfo/933-4510>

<http://www.walthers.com/exec/productinfo/933-4552>

<http://www.walthers.com/exec/productinfo/933-4553>

For more how-to help

For more ideas and information on modeling bridges, check out the following:

The Model Railroader's Guide to Bridges, Trestles & Tunnels

<http://www.walthers.com/exec/productinfo/400-12452>

Model Railroad Bridges & Trestles

<http://www.walthers.com/exec/productinfo/400-12474>

Bridge & Trestle Handbook

<http://www.walthers.com/exec/productinfo/15-99>

MAKING RAILROAD HISTORY™
WALTHERS®

